

WM-FX1

SERVICE MANUAL

Ver 1.1 2002.01

*E Model
Australian Model
Tourist Model*

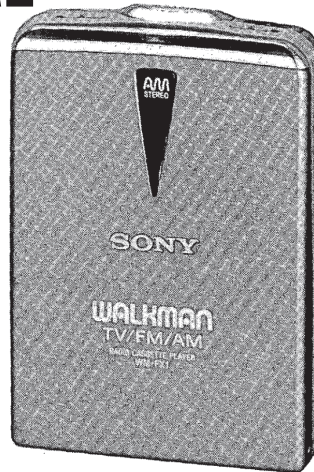

Model Name Using Similar Mechanism	NEW
Tape Transport Mechanism Type	MF-WMFX1-112

SPECIFICATIONS

Radio section

Frequency range

FM : 87.5 – 108 MHz (EXCEPT JE model)
76.0 – 90.0 MHz (JE model)
AM : 531 – 1,602 kHz (EXCEPT JE model)
531 – 1,710 kHz (JE model)
TV : 1ch – 12ch (MONO) (JE model)

Tape section

Frequency response (Dolby NR* off)

Playback: 30–18,000 Hz

Output

Headphones (REMOTE jack)
Load impedance 8–300 ohms

Power output

4 mW + 4 mW (16 ohms)
* Dolby noise reduction
manufactured under license
from Dolby Laboratories
Licensing Corporation.
"DOLBY" and the double-D
symbol  are trademarks of
Dolby Laboratories Licensing
Corporation.

General

Power requirements

1.5 V
Rechargeable battery
One R6 (size AA) battery

Dimensions (w/h/d)

Approx. 79.7 x 111.8 x 23.2 mm,
incl. projecting parts and controls

Mass

Approx. 180 g
Approx. 270 g incl. rechargeable
battery, headphones with remote
control and cassette

Supplied accessories

Battery case (1)
Stereo headphones with remote
control (1)
Ear adaptors (2)
Battery charger (1)
AC plug adaptor (1) (excluding
Australian model)
Rechargeable battery (NH-9WM
(S), 1.2 V, 1,000 mAh, Ni-MH) (1)
Carrying pouch (1)

Design and specifications are subject
to change without notice.

Battery life (Approx. hours)

	Sony alkaline AM3 (N)	Sony SUM-3 (NS)
Tape playback	25	8
Radio reception	27	8.5

Battery life (Approx. hours)

Rechargeable battery (NH-9WM (S))	
Tape playback	12
	36 (with Sony alkaline AM3 (N))
Radio reception	13
	38 (with Sony alkaline AM3 (N))

Battery life (Approx. hours)

Rechargeable battery (NC-6WM)	
Tape playback	8
Radio reception	8.5

Remove the rechargeable battery if
inserted and attach the battery case
and connect the AC power adaptor
(AC-E151G not supplied) to the DC
IN 1.5 V of the battery case and to
the mains. Do not use any other AC
power adaptor.



• Abbreviation
JE : Tourist model.

RADIO CASSETTE PLAYER

SONY®

9-959-783-12 Sony Corporation
2002A1600-1 Personal Audio Company
© 2002.1 Published by Sony Engineering Corporation

Notes on chip component replacement

- Never reuse a disconnected chip component.
- Notice that the minus side of a tantalum capacitor may be damaged by heat.

Flexible Circuit Board Repairing

- Keep the temperature of the soldering iron around 270 °C during repairing.
- Do not touch the soldering iron on the same conductor of the circuit board (within 3 times).
- Be careful not to apply force on the conductor when soldering or unsoldering.

SAFETY-RELATED COMPONENT WARNING !!

COMPONENTS IDENTIFIED BY MARK Δ OR DOTTED LINE WITH MARK Δ ON THE SCHEMATIC DIAGRAMS AND IN THE PARTS LIST ARE CRITICAL TO SAFE OPERATION. REPLACE THESE COMPONENTS WITH SONY PARTS WHOSE PART NUMBERS APPEAR AS SHOWN IN THIS MANUAL OR IN SUPPLEMENTS PUBLISHED BY SONY.

TABLE OF CONTENTS

<u>Section</u>	<u>Title</u>	<u>Page</u>
SECTION 1.	GENERAL	3
SECTION 2.	SERVICE NOTE	5
SECTION 3.	DISASSEMBLY	
3-1.	Case Assembly	7
3-2.	Cassette Lid Assembly	7
3-3.	Tuner Unit	7
3-4.	Reel Ornament	7
3-5.	Holder Assembly	8
3-6.	Main Board	8
3-7.	Belt	8
SECTION 4.	MECHANICAL ADJUSTMENTS	9
SECTION 5.	ELECTRICAL ADJUSTMENTS	9
SECTION 6.	DIAGRAMS	
6-1.	Block Diagram	10
6-2.	Printed Wiring Board — Main Board suffix No. 21 (JE model) —	13
6-3.	Printed Wiring Board — Main Board suffix No. 22 —	17
6-4.	Schematic Diagram	21
6-5.	Semiconductor Lead Layouts	25
6-6.	IC Pin Functions IC501 Tuner Controller/LCD Drive (μ PD1724GB)	26
	IC701 System Controller (MB8913PFV)	27
SECTION 7.	EXPLODED VIEWS	
7-1.	Cabinet Section	29
7-2.	Main Board Section	30
7-3.	Mechanism Section (MF-WMFX1-112)	31
SECTION 8.	ELECTRICAL PARTS LIST	32

- Abbreviation
JE : Tourist model.

SECTION 1

GENERAL

PARTS IDENTIFICATION

Tape Player and General section

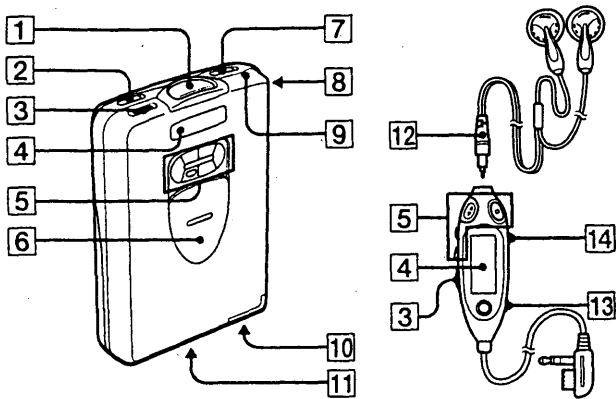

- 1 OPEN buttons
- 2 DOLBY NR switch
- 3 VOL (Volume) knob
- 4 Display window
- 5 Tape operation buttons
- 6 HOLD cover
- 7 (Play back mode) • BL SKIP (blank skip) switch
- 8 REMOTE jack
- 9 BATT (battery) indicator
- 10 Rechargeable battery case
- 11 Battery connecting points (for supplied battery case)
- 12 Micro plug
- 13 DBB/AVLS switch
- 14 HOLD switch

RADIO SECTION

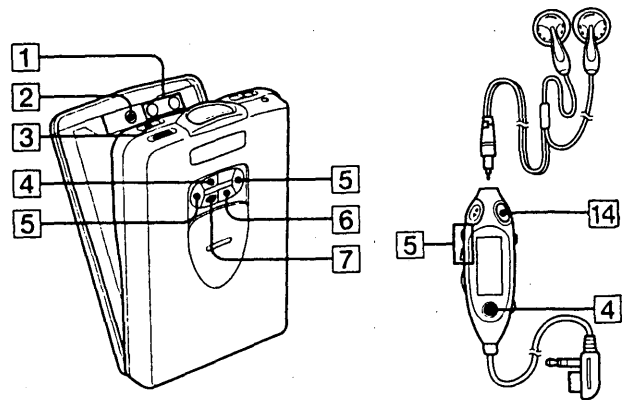

- 1 TUNE +, - button
- 2 ENTER button
- 3 MONO ST FM/AM switch
- 4 BAND • RADIO ON button
- 5 FF • +, REW • - button
- 6 • RADIO OFF button

This section is extracted from instruction manual.

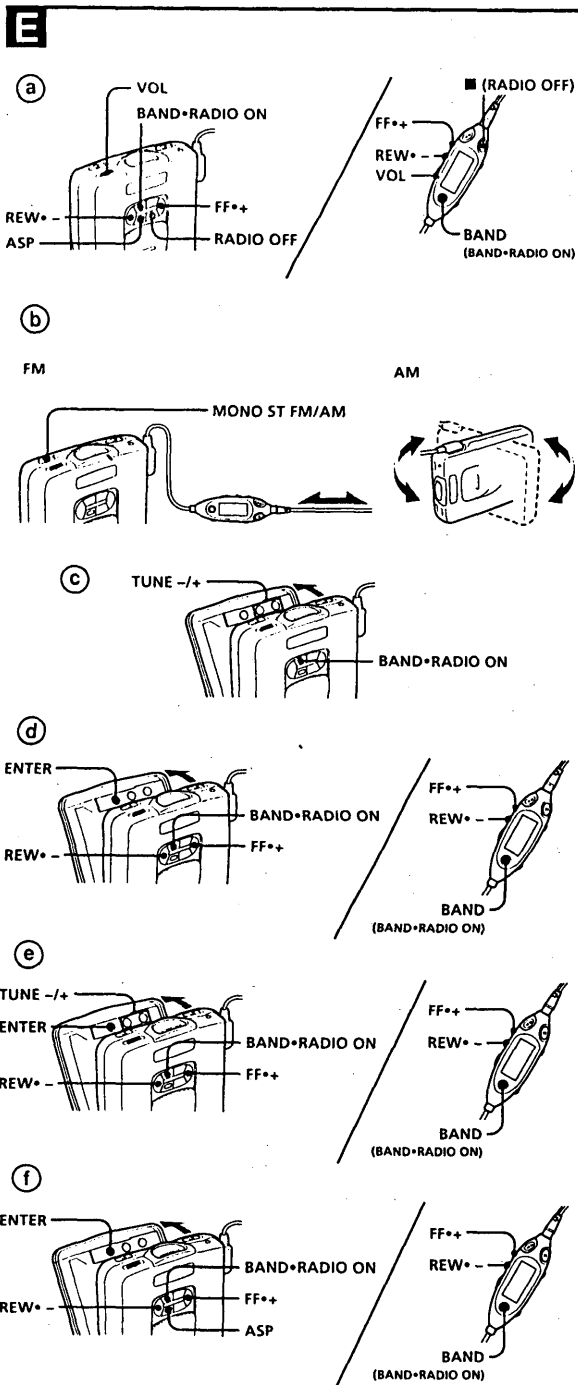

Listening to the Radio (see Fig. E-②)

- 1 Press BAND•RADIO ON to turn on the radio.
- 2 Press ASP* to preset the receivable stations. The Walkman starts searching and storing stations.
- 3 After the FM frequency and "PRESET 1" light, press BAND•RADIO ON repeatedly to select AM or FM.
- 4 Press FF•+ or REW•- to select the preset number you wish to listen to and adjust the volume using the VOL control. To turn off the radio, press RADIO OFF. Next time you listen to the radio in the same frequency area, you can skip step 2.

To improve the broadcast reception (see Fig. E-③)

- For AM: Reorient the Walkman horizontally.
- For FM: Extend the headphones cord, the aerial. If the reception is still not good, set the MONO ST (monaural/stereo) FM/AM selector* to MONO.
- * You tune to the AM stereo broadcast in Japan only.

What the ASP button does —ASP (Auto Station Preset function)

You can store and preset the receivable stations by simply pressing the ASP button. When you press the ASP button, the Walkman searches and stores receivable stations (both AM and FM) automatically. If the stations were not stored, or you want to preset stations manually, see "Tuning in the Radio Manually" or "Storing Radio Stations Manually and Receiving the Stations" as following.

Tuning in the Radio Manually (Manual tuning) (see Fig. E-④)

Turn on the radio and select the desired band. Then press TUNE +/- inside the cassette holder. If you press and hold TUNE +/- for more than a few seconds, the Walkman will start tuning the stations automatically.

Tuning in and Storing Radio Stations Automatically and Receiving the Stations (Auto-Memory Scanning function) (see Fig. E-⑤)

- 1 Press BAND•RADIO ON to turn on the radio.
- 2 Press BAND•RADIO ON repeatedly to select AM or FM.
- 3 Press ENTER inside the cassette holder until "A" appears in the display window. The Walkman starts searching and storing stations.

- 4 After "PRESET" and the preset number appear, tune in a station using FF•+ or REW•-.

Storing Radio Stations Manually and Receiving the Stations (Manual-Memory function) (see Fig. E-⑥)

- 1 Tune in a station you wish to store.
- 2 Press ENTER inside the cassette holder. "PRESET" and a preset number flash in the display window.
- 3 While "PRESET" and the preset number are flashing, select a preset number on which you wish to store a station using FF•+ or REW•-.
- 4 While "PRESET" and the preset number are flashing, press ENTER.
- 5 Tune in a station using FF•+ or REW•-.

Notes

- If you cannot complete step 3 or 4 while the indications are flashing, repeat from step 2.
- If you preset automatically using the ASP button, the stations stored will be erased.

Receiving Stations Outside Your Country (see Fig. E-⑦)

- 1 Press and hold ENTER inside the cassette holder and press BAND•RADIO ON to turn on the radio. "AREA 1" flashes in the display window.
- 2 While "AREA 1" is flashing, press FF•+ or REW•- repeatedly to select either area "USA" (USA and Canada) or "1"-"9" (Japan)* and then press ENTER.
- 3 Press ASP* to store the radio stations (both AM and FM) automatically. The Walkman starts searching and storing stations.
- 4 Press BAND•RADIO ON to select the desired band and press FF•+ or REW•- to select a station.

To cancel the stored station

Operate the Walkman according to the steps in "Storing Radio Stations Manually and Receiving the Stations" from step 1 to step 3. When you enter a preset number, select "-", and press the ENTER button while "-" is flashing.

SECTION 2

SERVICE NOTE

[Service Mode]

Mode which enables the mechanism to be operated with the MAIN board opened.

1. Setting

- 1) Refer to "Disassembly" and remove the cabinet and open the MAIN board.
- 2) Connect the MAIN board to the motor and plunger using a jumper wire. Use "Extension tool (1-769-143-11)" (one set 10 tools)" to make connection simple.
- 3) Short-circuit the TP101 by soldering. (TAPE SW)
- 4) Turn OFF the BL SKIP switch (S902) of the SW FLEXIBLE (MODE) board.
- 5) While short-circuiting the service mode land (TP104) using tweezers, etc. supply 1.2V to the battery + and - terminals from the stabilized power supply.

Note : After completing the repair, desolder and return the original state.

2. Preset State

This state must be set to set the PLAY, FF, and REW modes.

- 1) Check that the lever (NR SW) is at the center and N/R switch (S701) is at the center. If not, set the preset state as follows.
- 2) Move the N/R switch (S701) according to the side faced by the lever (NR SW).
- 3) The lever (NRSW) will work when the stabilized power supply is turned off once and turned on again. Move the N/R switch (S701) according to the movements of the lever and set to the center position.

Perform step 5) of the setting again. When timing is difficult, place the board on top, push S701 from the top with your finger and adjust so that S701 moves according to the movements of the lever (NR SW).

3. FF REW Mode

- 1) Check the "2. Preset State" and press the FF switch and REW switch.

4. PLAY Mode

- 1) Check the "2. Preset State".
- 2) When the <D> switch is pressed, the lever (NRSW) moves once to the N side and then moves to the R side. When the N/R switch (S701) is moved according to the movements of the lever (NR SW), the PLAY mode (R side) is set. When the <D> switch is pressed another time, and the N/R switch (S701) is moved according to the movements of the lever (NRSW), the PLAY mode (N side) is set.

Note 1 : If the above cannot be performed, start again from preset.

Note 2 : Use the remote control <D>, □, FF, and REW switches as much as possible. If the remote control is not available, do not touch S705 to S708 with the hand and use something with a round tip to press them.

Note 3 : By using a headphone, the timing for moving S701 can be known by the beep.

[MAIN Board]

— Conductor Side —

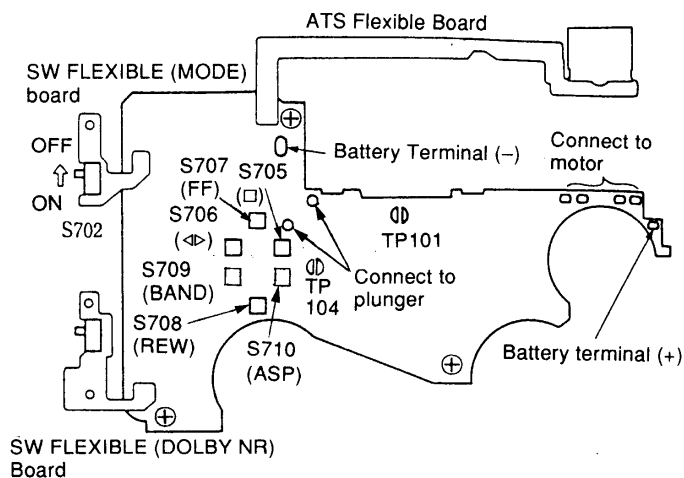

— Component Side —

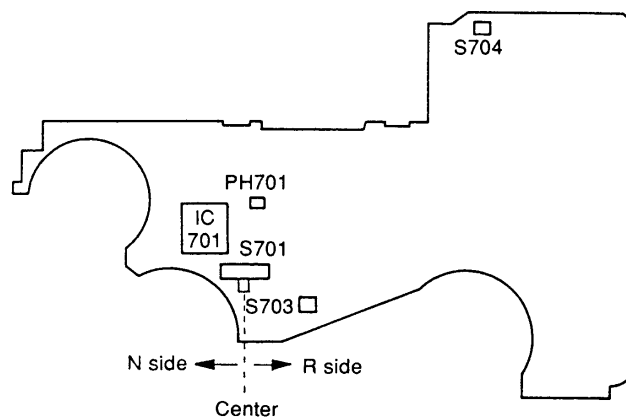

[Lever (NR SW)]

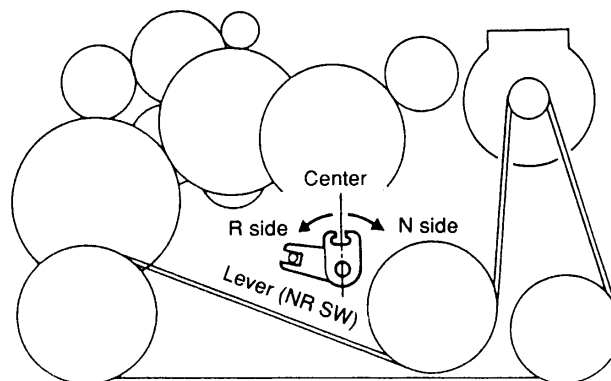

[Rotation system]

Rotation system during PLAY.

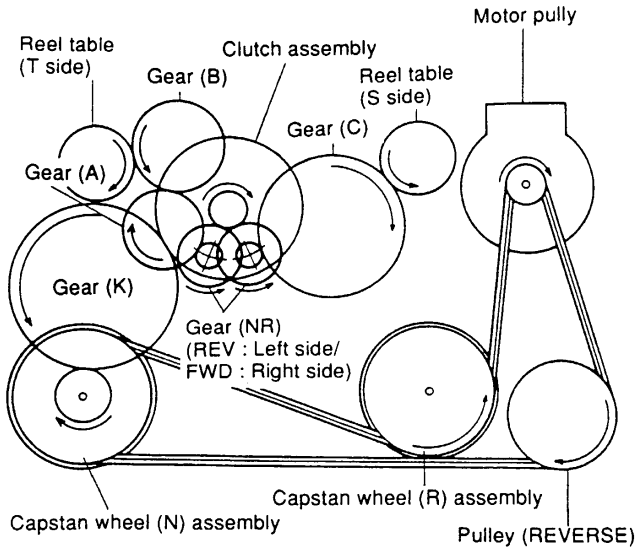

Rotation system during REW.

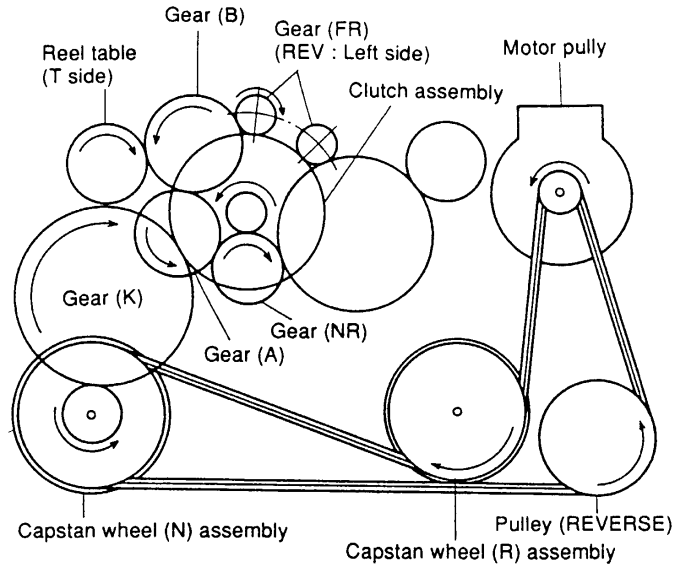

Rotation system during FF.

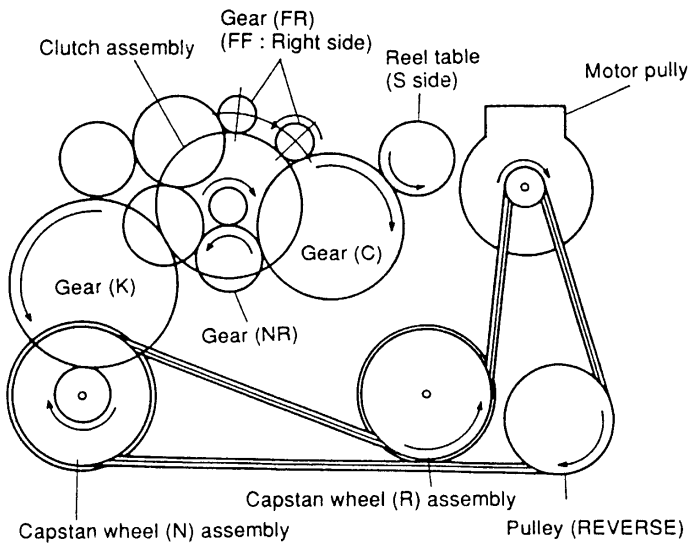

SECTION 3 DISASSEMBLY

• Remove by priority of number as ❶ in the figure.

3-1. CASE ASSEMBLY

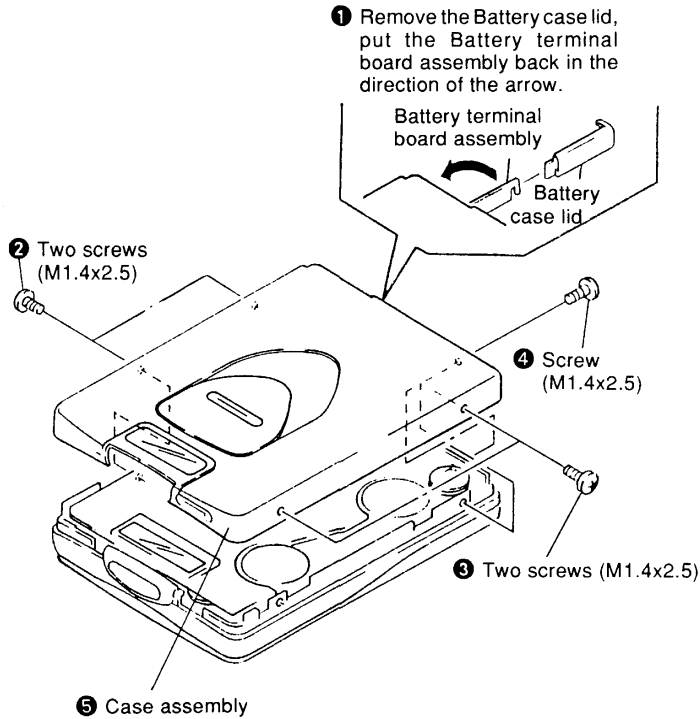

3-2. CASSETTE LID ASSEMBLY

❶ Remove the case assembly

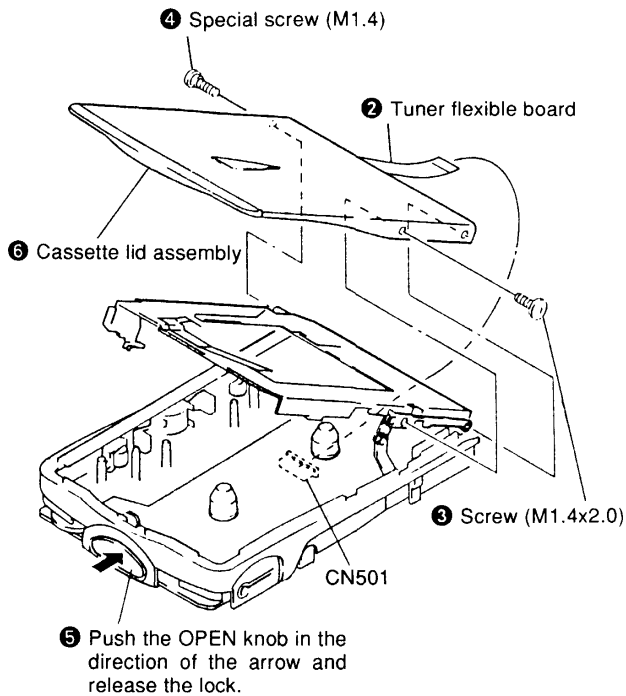

3-3. TUNER UNIT

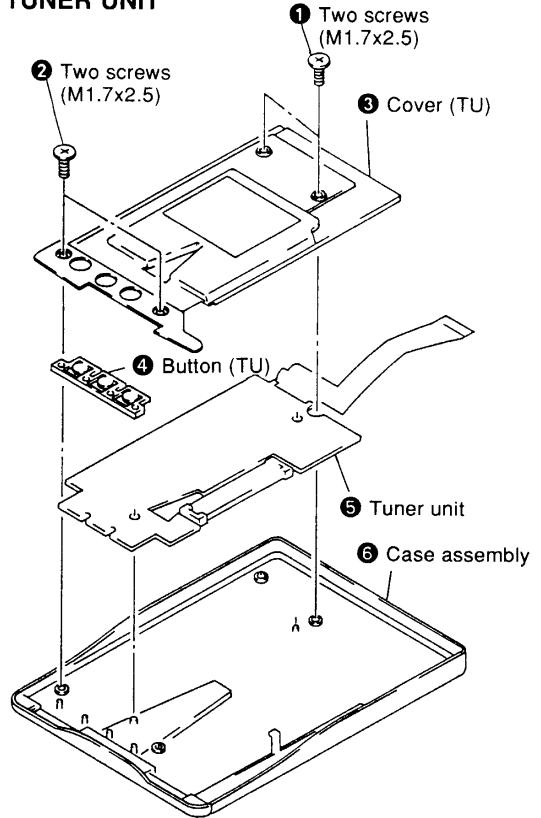

3-4. REEL ORNAMENT

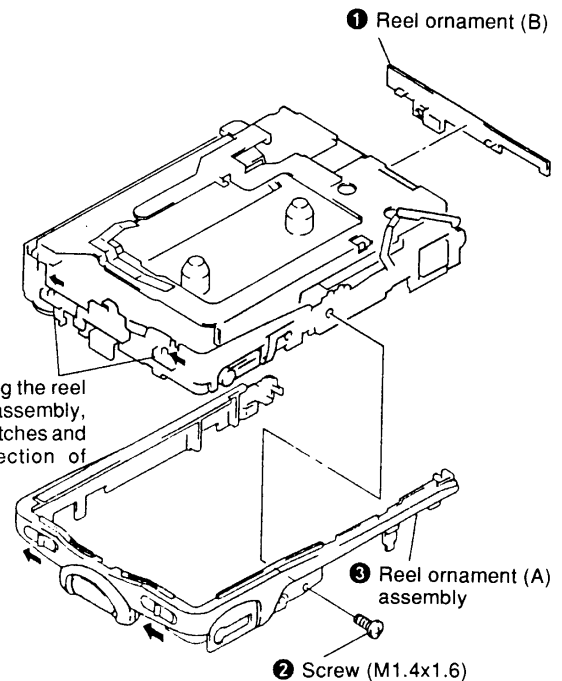

Note :

When mounting the reel ornament (A) assembly, set the two switches and knobs in direction of arrows.

3-5. HOLDER ASSEMBLY

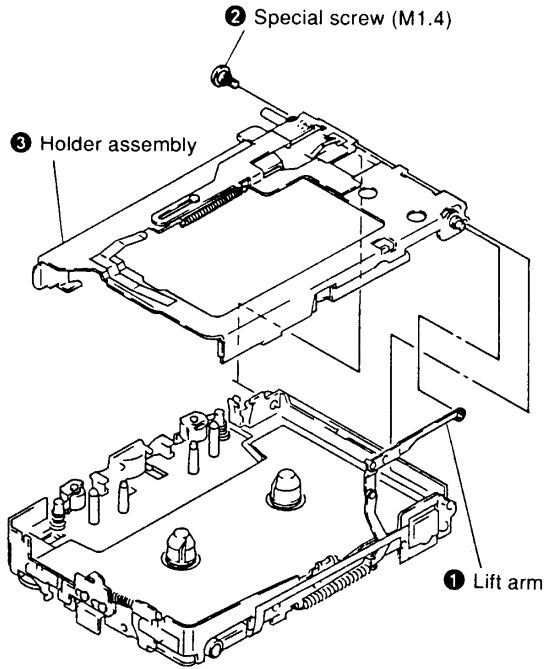

3-7. BELT

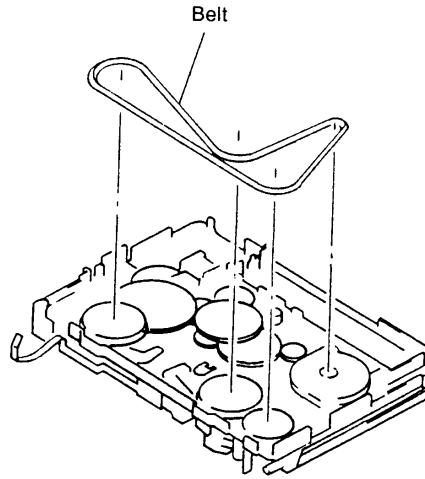

3-6. MAIN BOARD

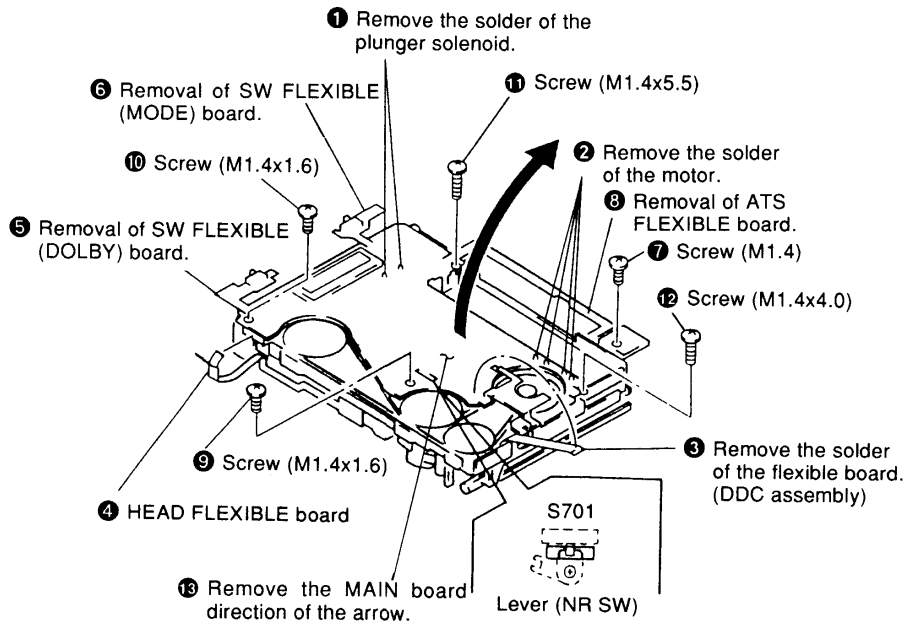

Note : Confirm if the switch lever installs itself in the groove of a lever (NR SW) for assembling.

**SECTION 4
MECHANICAL ADJUSTMENTS**

PRECAUTION

1. Before adjusting, clean the following parts with a piece of cotton swabbed with alcohol.
 - playback head
 - pinch roller
 - rubber feet
 - capstan
2. Disintegrate the playback head using a head demagnetizer.
3. Do not use an ungrounded screwdriver for adjustments.
4. After adjusting, apply screw-locking compound onto the adjusted parts.
5. Unless specified otherwise, use a specified voltage (1.5V) to perform the adjustments.

[Torque Measurement]

Mode	Torque Meter	Meter Reading
FWD	CQ 100C	18 — 28 g · cm
FWD Black sensor		0.5 — 1.0 g · cm
REV		18 — 28 g · cm
REV Black sensor	CQ 100C	0.5 — 1.0 g · cm
FF		
REW	CQ 2018	More than 40 g · cm

**SECTION 5
ELECTRICAL ADJUSTMENTS**

PRECAUTION

1. Specified voltage: 1.5V.
2. Switch position:
 - DOLBY NR switch: OFF
 - EX (DIB) switch: NORM (Only remote control)

[Cassette Section]

Type	Signal	Used for
WS-45A	3 kHz, 10 dB	Tap Speed Adjustment

[USB = 0.75V]

[Tap speed adjustment]

Procedure:

1. Play back WS-45A (tape center part) in the FWD state and adjust RW61 so that the frequency counter reading becomes MAX ± 10 Hz.
2. Play back WS-45A (tape center) in the REV state. Check that the frequency counter reading is within 2.5% of the reading of step 1.

Adjustment Point:

MAIN BOARD (Side B)

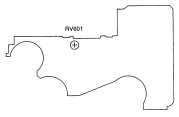

**SECTION 6
DIAGRAMS**

6-1. BLOCK DIAGRAM

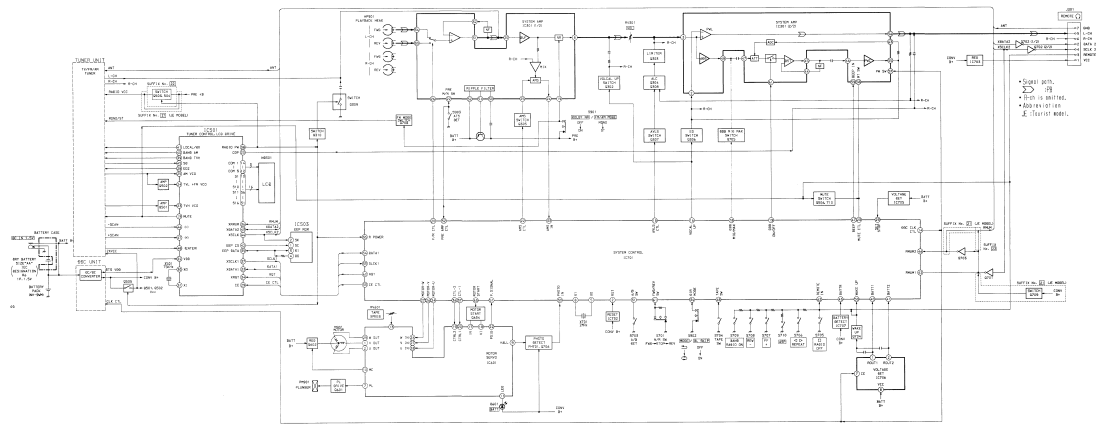

6-3. PRINTED WIRING BOARD — MAIN board suffix No. 22 —
 — See page 25 for Semiconductor Lead Layouts.

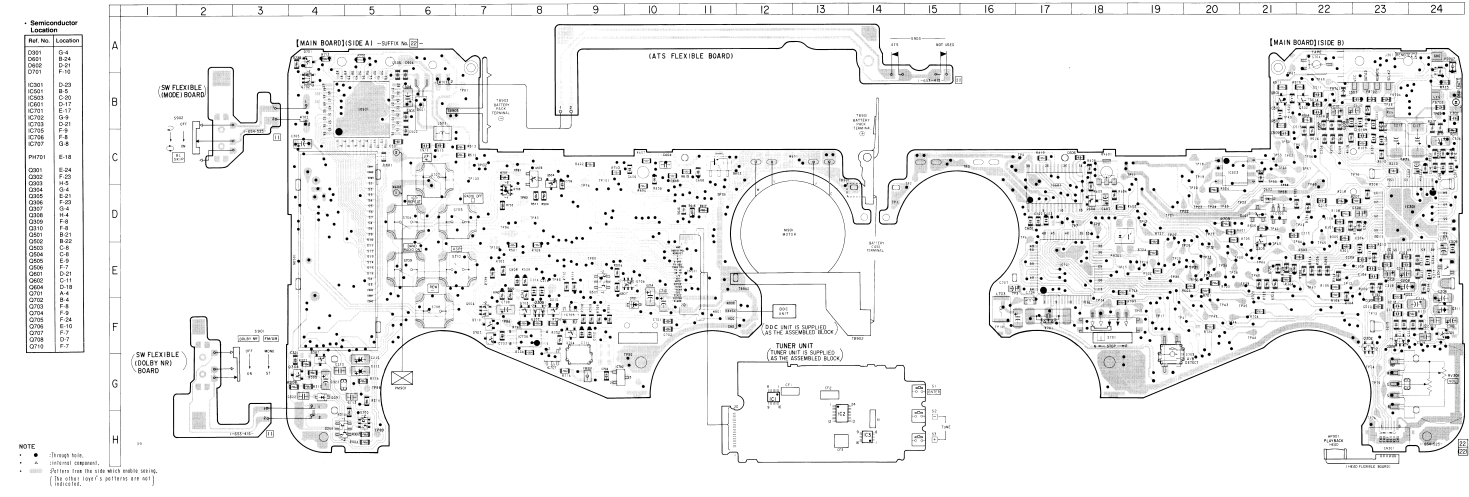

6-5. SEMICONDUCTOR LEAD LAYOUTS

LB1679V-TLM

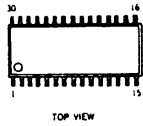

**TA2040AFN
TA8182FN**



XN4604-TX

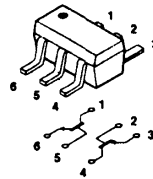

XP4401

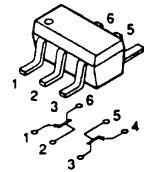

**MB89133PFV-G-229BND
TA2084F**

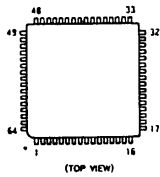

TA8153FN

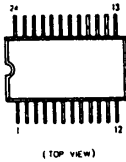

XN4608

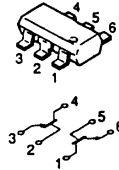

2SB1302-S

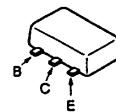

**MM1276XWBE
S-29L221ADFE-TB**

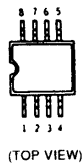

μPD1724GB-688-1A7

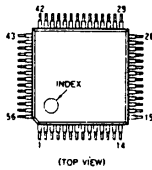

XP1115

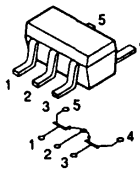

CL-200HR-C-TSL

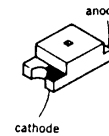

PST9010NL

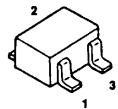

XC61AN1402MX

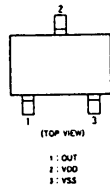

XP1215-TXE

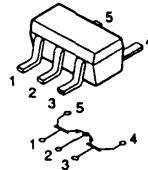

MA110

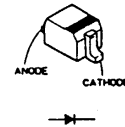

PST9018NL

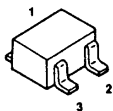

**UN5210-R
UN5215-RS-TX
2SA1586-YG
2SB1295-UL6
2SC4154-F
2SC4178-F13
2SD1935-CT6**

XP4215-TXE

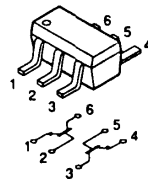

**MA729
MA8110**

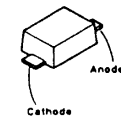

S-81211SG-QA-T1

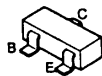
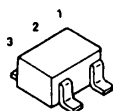

XP4315-TXE

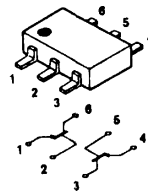

NJL5183K-F20-TE1

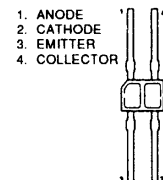

6-6. IC PIN FUNCTIONS

• IC501 TUNER CONTROLLER/LCD DRIVE (μ PD1724GB)

Pin No.	Pin Name	I/O	Function
1 to 10	S10 to S1	O	LCD segment signal output pin
11	NC	–	Not used
12 to 14	COM3 to COM1	O	LCD common signal output pin
15	VSS3	–	Pins connecting capacitors for doubler circuits generating the LCD drive voltage
16	CAP2	–	
17	CAP1	–	
18	VSS2	–	
19	MUTE	O	Generates 1.12 kHz pulses when using as a VDP
20	CGP	O	BEEP signal output terminal
21	NC	–	Not used
22	VDD	–	The internal reset circuit functions when supplied with 0V to 1.5V
23	TVH VCO	I	Partial oscillation frequency input pin (direct dividing method) (HIGH IMP when CE is low)
24	TVL+FM VCO	I	Partial oscillation frequency input pin (pulse swallow method) (PULL DOWN when CE is low)
25	AM VCO	I	
26	VSS1	–	GND
27	E01	O	Not used
28	E02	O	When the frequency obtained by frequency dividing the partial oscillation frequency is higher than the reference frequency: HIGH output. When Lower: LOW output. When the same: HIGH-IMP.
29	CE	I	The internal reset circuit functions when LOW becomes HIGH
30	XO	O	Connected to the liquid crystal oscillator Oscillates 75 kHz liquid crystals
31	XI	I	
32	VSS4	–	Connected to the regulator circuit capacitor
33	XDATA1	I	Data from the main microprocessor
34	XRQT	I	Pin inputting requests from the main microprocessor
35	EEP DATA	I/O	Pin for communicating data with EEPROM
36	XRMUM	I	With remote control: HIGH potential. No remote control: LOW potential
37	XSCLK1	O	Serial clock output pin for communicating with the main microprocessor
38	RADIO POWER	O	HIGH potential when RADIO is ON
39	BAND TVH	O	Become HIGH potential when TV channels 4 to 12 are received
40	BAND AM	O	Outputs HIGH potential only during AM reception
41	LOCAL/DX	O	LOCAL: HIGH output. DX: LOW output.
42	EEP CS	O	CS control pin for the EEPROM
43	XDATA2	O	Remote control data output pin
44	XSCLK2	O	Remote control EEPROM serial clocks
45	SD	I	No broadcasting station: HIGH output. With: LOW output
46	(–)	I	Manual reception frequency down button
47	(+)	I	Manual reception frequency up button
48	(ENTER)	I	Used for manual preset, etc.
49, 50	NC	–	Not used
51 to 56	S16 to S11	O	LCD segment signal output pin

• IC701 System Controller (MB8913PFV)

Pin No.	Pin Name	I/O	Function
1	AVCC	–	Analog section power supply
2	RST	I	Reset
3	MODE0	I	Operation mode specified input (Connected to GND)
4	MODE1	I	Operation mode specified input (Connected to GND)
5	X0	–	High speed clock connection (2 MHz ceramics oscillator)
6	NC	–	Not used
7	NC	–	Not used
8	X1	–	High speed clock connection (2 MHz ceramics oscillator)
9	VCC	–	Logic section power supply
10	X0A	–	Low speed clock connection (Not used)
11	NC	–	Not used
12	NC	–	Not used
13	X1A	–	Low speed clock connection (Not used)
14	DDC CLK CTL	O	DDC oscillation frequency change output (L:Waiting state)
15	AVLS CTL	O	AVLS control output (AVLS:L)
16	VOCAL UP	O	Sound quality control output (VOCAL UP:H)
17	NC	–	Not used
18	DBB MID/MAX CTL	O	Sound quality control output (DBB1:H)
19	DBB ON/OFF CTL	O	Sound quality control output (DBB1, DBB2:H)
20	F/R CTL	O	FWD:H, REV:L
21	NC	–	Not used
22	AMS CTL	O	AMS sensitivity control output (FF/REW:H)
23	MUTE CTL	O	AUDIO POWER AMP MUTING (MUTE:L)
24	MOTOR-U	O	Motor U phase control output
25	VSS	–	GND
26	MOTOR-V	O	Motor V phase control output
27	MOTOR-W	O	Motor W phase control output
28	NC	–	Not used
29	SET STOP	I	PLAY power failure STOP input
30	PHOTO IN	I	Rotation detection input
31	A/B SW	I	Tape A/B side detection SW input (Side A top:L, Side B top:H)
32	NC	–	Not used
33	AMS IN	I	Recording detection input (Music:H)
34	DIR MODE	I	DIRECTION MODE selection and BL, SKIP ON/OFF input SHUT OFF, BL SKIP OFF = L, ENDLESS, BL SKIP ON = H
35	R POWER	I	RADIO ON detection input
36	CTL2	O	Servo IC control output
37	CTL1	O	Servo IC control output
38	NC	–	Not used
39	NC	–	Not used

Pin No.	Pin Name	I/O	Function
40	BATT1	I	Power failure indication input { LEVEL1 : BATT1 = H, BATT2 = H (LOW) LEVEL2 : BATT1 = H, BATT2 = L (MIDDLE) LEVEL3 : BATT1 = L, BATT2 = L (HIGH)}
41	BATT2	I	
42	RMUM	I	
43	BATTR	I	Radio BATT detection input
44	NC	-	Not used
45	NC	-	Not used
46	RMUM2	I	WAKE UP when the setting is changed from "without remote control" to "with remote control"
47	BEEP	O	Beep sound output
48	TAPE SW	I	Tape presence detection input (Present:L)
49	NC	-	Not used
50	WAKE UP	I	Stop mode release interruption
51	P-SIGNAL	I	Motor rotation control
52	PRE AMP CTL	I/O	RADIO : H, OTHER : L
53	CE CTL	O	DTS CHIP ENABLE control output
54	DATA1	O	Serial data output
55	SCLK1	I	Serial clock input
56	NC	-	Not used
57	AVSS	-	Analog section (GND)
58	NC	-	Not used
59	AVR	-	Analog section reference potential input
60	RQT	O	Request output for communicating with DTS
61	FWD/REV SW	I	F/R SW input (Analog input)
62	REMOTE IN	I	Key input (Analog input)
63	MOTOR START	O	Motor start-up control output (Motor start-up:Outputs L for 200 ms)
64	NC	-	Not used

7-3. MECHANISM SECTION (MF-WMFX1-112)

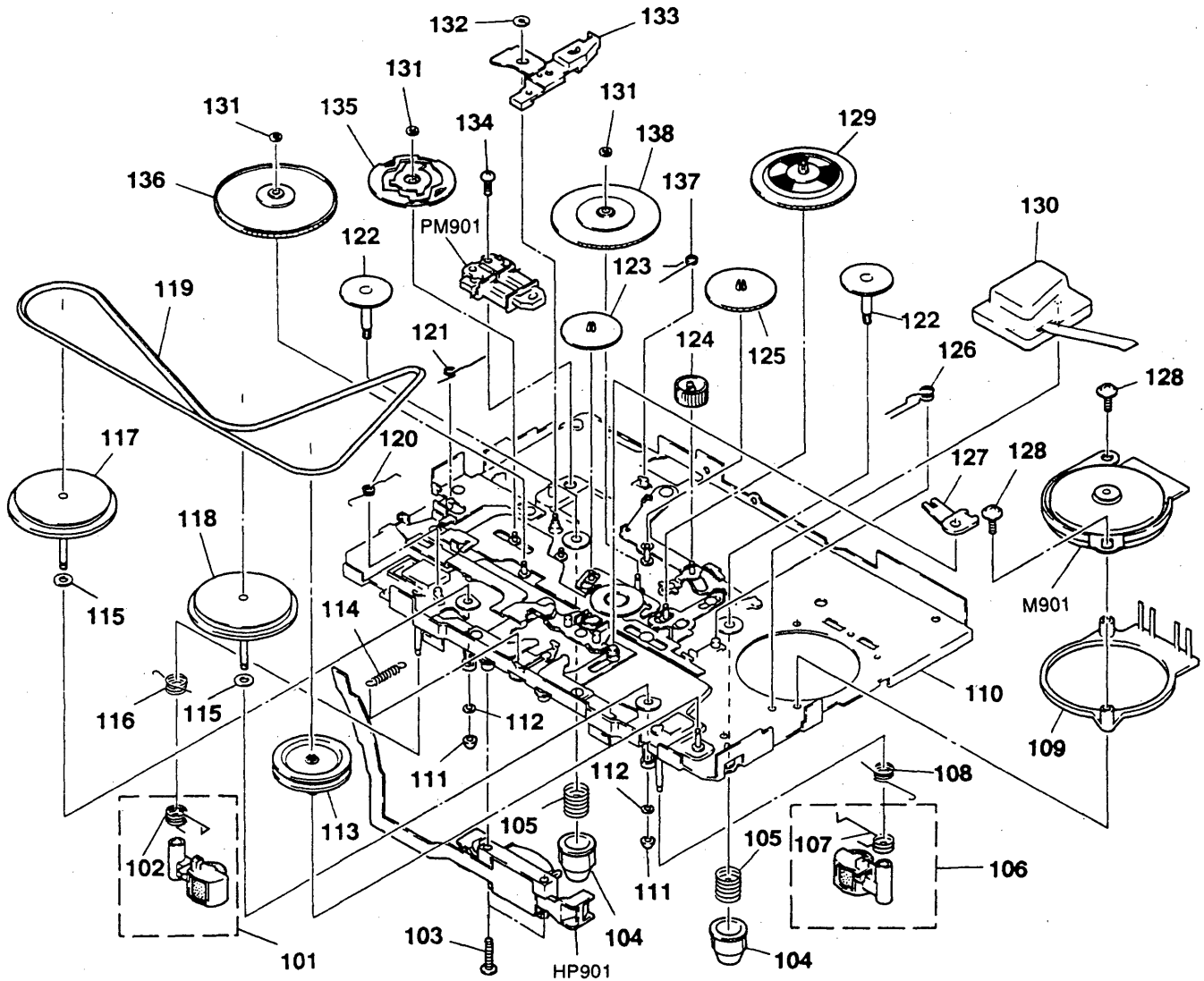

Ref. No.	Part No.	Description	Remark	Ref. No.	Part No.	Description	Remark
101	X-3368-776-1	PINCH LEVER (N) ASSY		122	3-365-801-01	TABLE, REEL	
102	3-916-341-01	SPRING (PINCH N)		123	3-916-353-01	GEAR (A)	
103	3-704-413-31	SCREW (M1.4X7.2)		124	3-916-352-01	GEAR (FR)	
104	3-916-357-01	GEAR (REEL)		125	3-916-354-01	GEAR (B)	
105	3-366-058-01	SPRING, COMPRESSION		126	3-916-347-01	SPRING (NR), TORSION	
106	X-3368-777-1	PINCH LEVER (R) ASSY		127	3-916-339-01	LEVER (NRSW)	
107	3-916-342-01	SPRING (PINCH R)		128	3-358-455-11	SCREW, PRECISION WASHER HEAD	
108	3-916-344-01	SPRING (RETURN R)		129	A-3042-517-A	GEAR (C)	
* 109	3-916-337-01	DECK, FIXED, TERMINAL		130	A-3042-533-A	DDC ASSY	
110	X-3370-090-1	CHASSIS ASSY		131	3-338-645-31	WASHER (0.8-2.5)	
111	3-366-017-01	BUSHING (CAPSTAN)		132	3-348-953-41	WASHER	
112	3-918-943-01	WASHER, STOPPER		133	3-916-338-01	LEVER (TRIGGER)	
113	3-916-350-01	PULLEY (REVERSE)		134	3-366-521-51	SCREW (M1.4X3.5)	
114	3-916-346-01	SPRING, TENSION		135	3-916-356-01	GEAR (CAM)	
115	3-386-694-01	WASHER		136	3-916-351-01	GEAR (K)	
116	3-916-343-01	SPRING (RETURN N)		137	3-916-348-01	SPRING (TRIGGER), TORSION	
117	X-3368-779-1	WHEEL (N) ASSY, CAPSTAN		138	X-3368-780-1	CLUTCH ASSY	
118	X-3368-778-1	WHEEL (R) ASSY, CAPSTAN		M901	1-698-368-11	MOTOR	
119	3-916-349-01	BELT		HP901	1-500-091-21	HEAD, MAGNETIC (PLAYBACK)	
120	3-916-345-01	SPRING (LOCK LEVER)		PM901	1-454-674-11	SOLENOID, PLUNGER	
121	3-916-340-01	SPRING (EJECT), TORSION					

NOTE:

The components identified by mark Δ or dotted line with mark Δ are critical for safety.
Replace only with part number specified.

When indicating parts by reference number, please include the board name.

- Due to standardization, replacements in the parts list may be different from the parts specified in the diagrams or the components used on the set.
- -XX, -X mean standardized parts, so they may have some difference from the original one.
- Items marked "*" are not stocked since they are seldom required for routine service. Some delay should be anticipated when ordering these items.
- RESISTORS
All resistors are in ohms
METAL: Metal-film resistor
METAL OXIDE: Metal Oxide-film resistor
F: nonflammable

- SEMICONDUCTORS
In each case, u: μ , for example:
uA...: μ A..., uPA...: μ PA..., uPB...: μ PB...,
uPC...: μ PC..., uPD...: μ PD...
- CAPACITORS
uF: μ F
- COILS
uH: μ H
- Abbreviation
AUS : Australian model
JE : Tourist model

Ref. No.	Part No.	Description	Remark	Ref. No.	Part No.	Description	Remark
	1-653-415-11	ATS FLEXIBLE BOARD *****		C208	1-162-970-11	CERAMIC CHIP 0.01uF 10%	25V
		< SWITCH >		C209	1-165-112-11	CERAMIC CHIP 0.33uF	16V
S903	1-572-580-11	SWITCH, LEAF (ATS)		C210	1-109-847-11	TANTAL. CHIP 0.47uF 10%	16V
		*****		C211	1-162-968-11	CERAMIC CHIP 0.0047uF 10%	50V
	A-3061-045-A	MAIN BOARD, COMPLETE *****		C212	1-135-151-21	TANTALUM CHIP 4.7uF 20%	4V
	1-537-646-11	CONDUCTIVE BOARD, CONNECTION		C213	1-164-505-11	CERAMIC CHIP 2.2uF	16V
	3-841-069-02	SPACER		C214	1-165-128-11	CERAMIC CHIP 0.22uF	16V
*	3-919-509-01	HOLDER (LCD)		C215	1-109-996-11	CERAMIC CHIP 1uF	6.3V
		< CAPACITOR >		C216	1-109-996-11	CERAMIC CHIP 1uF	6.3V
C101	1-162-963-11	CERAMIC CHIP 680PF 10%	50V	C217	1-109-930-11	TANTAL. CHIP 220uF 20%	2.5V
C102	1-162-963-11	CERAMIC CHIP 680PF 10%	50V	C218	1-109-996-11	CERAMIC CHIP 1uF	6.3V
C103	1-107-815-11	TANTAL. CHIP 2.2uF 20%	4V	C219	1-165-128-11	CERAMIC CHIP 0.22uF	16V
C104	1-164-227-11	CERAMIC CHIP 0.022uF 10%	25V	C220	1-164-227-11	CERAMIC CHIP 0.022uF 10%	25V
C105	1-164-677-11	CERAMIC CHIP 0.033uF 10%	16V	C221	1-162-968-11	CERAMIC CHIP 0.0047uF 10%	50V
C106	1-162-965-11	CERAMIC CHIP 0.0015uF 10%	50V	C301	1-165-128-11	CERAMIC CHIP 0.22uF	16V
C107	1-164-174-11	CERAMIC CHIP 0.0082uF 10%	25V	C302	1-165-112-11	CERAMIC CHIP 0.33uF	16V
C108	1-162-970-11	CERAMIC CHIP 0.01uF 10%	25V	C303	1-109-936-11	TANTAL. CHIP 3.3uF 20%	2.5V
C109	1-165-112-11	CERAMIC CHIP 0.33uF	16V	C304	1-135-316-11	TANTAL. CHIP 22uF 20%	2.5V
C110	1-109-847-11	TANTAL. CHIP 0.47uF 10%	16V	C305	1-109-934-11	TANTAL. CHIP 4.7uF 20%	4V
C111	1-162-968-11	CERAMIC CHIP 0.0047uF 10%	50V	C306	1-104-847-11	TANTAL. CHIP 22uF 20%	4V
C112	1-135-151-21	TANTALUM CHIP 4.7uF 20%	4V	C307	1-135-337-11	TANTAL. CHIP 1uF 20%	6.3V
C113	1-164-505-11	CERAMIC CHIP 2.2uF	16V	C308	1-135-337-11	TANTAL. CHIP 1uF 20%	6.3V
C114	1-165-128-11	CERAMIC CHIP 0.22uF	16V	C309	1-162-961-11	CERAMIC CHIP 330PF 10%	50V
C115	1-109-996-11	CERAMIC CHIP 1uF	6.3V	C311	1-107-983-11	TANTAL. CHIP 10uF 20%	2.5V
C116	1-109-996-11	CERAMIC CHIP 1uF	6.3V	C312	1-164-489-11	CERAMIC CHIP 0.22uF 10%	16V
C117	1-109-930-11	TANTAL. CHIP 220uF 20%	2.5V	C313	1-109-996-11	CERAMIC CHIP 1uF	6.3V
C118	1-109-996-11	CERAMIC CHIP 1uF	6.3V	C314	1-109-996-11	CERAMIC CHIP 1uF	6.3V
C119	1-165-128-11	CERAMIC CHIP 0.22uF	16V	C315	1-164-489-11	CERAMIC CHIP 0.22uF 10%	16V
C120	1-164-227-11	CERAMIC CHIP 0.022uF 10%	25V	C316	1-135-218-11	TANTAL. CHIP 4.7uF 20%	2.5V
C121	1-162-968-11	CERAMIC CHIP 0.0047uF 10%	50V	C317	1-165-128-11	CERAMIC CHIP 0.22uF	16V
C201	1-162-963-11	CERAMIC CHIP 680PF 10%	50V	C318	1-135-337-11	TANTAL. CHIP 1uF 20%	6.3V
C202	1-162-963-11	CERAMIC CHIP 680PF 10%	50V	C319	1-135-316-11	TANTAL. CHIP 22uF 20%	2.5V
C203	1-107-815-11	TANTAL. CHIP 2.2uF 20%	4V	C321	1-162-995-11	CERAMIC CHIP 0.022uF	50V
C204	1-164-227-11	CERAMIC CHIP 0.022uF 10%	25V	C322	1-164-005-11	CERAMIC CHIP 0.47uF	25V
C205	1-164-677-11	CERAMIC CHIP 0.033uF 10%	16V	C323	1-135-219-11	TANTAL. CHIP 15uF 20%	2.5V
C206	1-162-965-11	CERAMIC CHIP 0.0015uF 10%	50V	C501	1-164-360-11	CERAMIC CHIP 0.1uF	16V
C207	1-164-174-11	CERAMIC CHIP 0.0082uF 10%	25V	C502	1-162-964-11	CERAMIC CHIP 0.001uF 10%	50V
				C503	1-164-360-11	CERAMIC CHIP 0.1uF	16V
				C504	1-104-847-11	TANTAL. CHIP 22uF 20%	4V
				C505	1-164-237-11	CERAMIC CHIP 16PF 5%	50V
				C506	1-162-912-11	CERAMIC CHIP 7PF 0.5PF	50V
				C507	1-164-360-11	CERAMIC CHIP 0.1uF	16V

Ref. No.	Part No.	Description	Remark	Ref. No.	Part No.	Description	Remark	
C508	1-164-360-11	CERAMIC CHIP	0. 1uF	16V	FB706	1-500-113-11	BEAD, FERRITE (CHIP)	
C509	1-162-962-11	CERAMIC CHIP	470PF	10%	50V	FB707	1-414-235-11	INDUCTOR, FERRITE BEAD
C510	1-162-962-11	CERAMIC CHIP	470PF	10%	50V		< HEAD >	
C511	1-162-941-11	CERAMIC CHIP	10PF	0. 5PF	50V			
C512	1-162-962-11	CERAMIC CHIP	470PF	10%	50V	HP901	1-500-091-21	HEAD, MAGNETIC (PLAYBACK)
C513	1-162-970-11	CERAMIC CHIP	0. 01uF	10%	25V		< IC >	
C514	1-162-936-11	CERAMIC CHIP	5PF	0. 25PF	50V	IC301	8-759-295-97	IC TA2084F
C515	1-162-941-11	CERAMIC CHIP	10PF	0. 5PF	50V	IC501	8-759-329-93	IC uPD1724GB-688-1A7
C516	1-162-964-11	CERAMIC CHIP	0. 001uF	10%	50V	IC503	8-759-499-36	IC S-29L221-S
C601	1-162-970-11	CERAMIC CHIP	0. 01uF	10%	25V	IC601	8-759-271-28	IC LB1679V-TLM
C602	1-162-970-11	CERAMIC CHIP	0. 01uF	10%	25V	IC701	8-759-294-24	IC MB89133LPFV-G-229BND
C603	1-162-970-11	CERAMIC CHIP	0. 01uF	10%	25V	IC702	8-759-163-52	IC XC61AN1402MX
C604	1-164-695-11	CERAMIC CHIP	0. 0022uF	5%	50V	IC703	8-759-280-84	IC S-81211SG-QA-T1
C605	1-165-176-11	CERAMIC CHIP	0. 047uF	10%	16V	IC705	8-759-280-85	IC PST9010NL
C606	1-164-004-11	CERAMIC CHIP	0. 1uF	10%	25V	IC706	8-759-291-99	IC MM1276XWBE
C607	1-109-936-11	TANTAL. CHIP	3. 3uF	20%	2. 5V	IC707	8-759-296-60	IC PST9018NL
C608	1-162-966-11	CERAMIC CHIP	0. 0022uF	10%	50V		< JACK >	
C701	1-162-912-11	CERAMIC CHIP	7PF	0. 5PF	50V	J301	1-766-512-21	JACK 7P (REMOTE ())
C702	1-162-912-11	CERAMIC CHIP	7PF	0. 5PF	50V		< JUMPER RESISTOR >	
C703	1-109-996-11	CERAMIC CHIP	1uF		6. 3V	JC501	1-216-864-11	METAL CHIP 0 5% 1/16W
C704	1-109-996-11	CERAMIC CHIP	1uF		6. 3V	JC601	1-216-864-11	METAL CHIP 0 5% 1/16W
C705	1-109-996-11	CERAMIC CHIP	1uF		6. 3V		(JE SUFFIX No. 21)	
C706	1-135-337-11	TANTAL. CHIP	1uF	20%	6. 3V	JC701	1-216-864-11	METAL CHIP 0 5% 1/16W
				(JE SUFFIX No. 21)		JC702	1-216-864-11	METAL CHIP 0 5% 1/16W
C707	1-107-815-11	TANTAL. CHIP	2. 2uF	20%	4V	JC703	1-249-997-11	CARBON MELF 0 5% 1/8W
C708	1-135-221-11	TANTAL. CHIP	3. 3uF	20%	4V		< COIL >	
C709	1-162-970-11	CERAMIC CHIP	0. 01uF	10%	25V	L501	1-410-213-51	INDUCTOR CHIP 56uH
C710	1-104-847-11	TANTAL. CHIP	22uF	20%	4V	L502	1-412-965-11	INDUCTOR 68N
C711	1-162-964-11	CERAMIC CHIP	0. 001uF	10%	50V	L703	1-414-431-11	INDUCTOR 10uH
C712	1-162-964-11	CERAMIC CHIP	0. 001uF	10%	50V	L704	1-412-006-31	INDUCTOR CHIP 10uH
C713	1-104-847-11	TANTAL. CHIP	22uF	20%	4V		< MOTOR >	
C714	1-104-847-11	TANTAL. CHIP	22uF	20%	4V	M901	1-698-368-11	MOTOR
		< CONNECTOR >					< LIQUID CRYSTAL DISPLAY >	
CN301	1-695-942-21	CONNECTOR, FPC (ZIF) 6P				ND501	1-810-704-11	DISPLAY PANEL, LIQUID CRYSTAL
* CN501	1-770-033-21	CONNECTOR, FPC (ZIF) 20P					< PHOTO INTERRUPTER >	
		< DIODE >				PH701	8-749-925-05	REFLECTOR NJL5183KA-F20-TE1
D301	8-719-420-51	DIODE MA729					< PLUNGER SOLENOID >	
D601	8-719-989-53	DIODE CL-200HR-C-TSL (BATT)				PM901	1-454-674-11	SOLENOID, PLUNGER
D602	8-719-404-46	DIODE MA110						
D701	8-719-423-17	DIODE MA8110 (SUFFIX No. 22)						
		< FERRITE BEAD >						
FB301	1-500-113-11	BEAD, FERRITE (CHIP) (SUFFIX No. 22)						
FB701	1-500-113-11	BEAD, FERRITE (CHIP)						
FB702	1-500-113-11	BEAD, FERRITE (CHIP)						
FB703	1-500-113-11	BEAD, FERRITE (CHIP)						
FB704	1-500-113-11	BEAD, FERRITE (CHIP)						
FB705	1-500-113-11	BEAD, FERRITE (CHIP)						

MAIN

Ref. No.	Part No.	Description	Remark	Ref. No.	Part No.	Description	Remark
< TRANSISTOR >				R203	1-216-839-11	METAL CHIP	33K 5% 1/16W
Q301	8-729-807-87	TRANSISTOR	2SB1295-UL6	R204	1-216-812-11	METAL CHIP	180 5% 1/16W
Q302	8-729-426-36	TRANSISTOR	XP1215-TXE	R205	1-216-831-11	METAL CHIP	6.8K 5% 1/16W
Q303	8-729-427-70	TRANSISTOR	XP4401	R206	1-216-847-11	METAL CHIP	150K 5% 1/16W
Q304	8-729-602-21	TRANSISTOR	2SC4154-F	R207	1-216-839-11	METAL CHIP	33K 5% 1/16W
Q305	8-729-421-77	TRANSISTOR	UN5210-R	R208	1-216-839-11	METAL CHIP	33K 5% 1/16W
Q306	8-729-426-36	TRANSISTOR	XP1215-TXE	R209	1-216-834-11	METAL CHIP	12K 5% 1/16W
Q307	8-729-421-77	TRANSISTOR	UN5210-R	R210	1-216-852-11	METAL CHIP	390K 5% 1/16W
Q308	8-729-425-25	TRANSISTOR	XN4604-TX	R211	1-216-825-11	METAL CHIP	2.2K 5% 1/16W
Q309	8-729-426-36	TRANSISTOR	XP1215-TXE	R213	1-216-825-11	METAL CHIP	2.2K 5% 1/16W
Q310	8-729-421-77	TRANSISTOR	UN5210-R	R214	1-216-824-11	METAL CHIP	1.8K 5% 1/16W
Q501	8-729-117-72	TRANSISTOR	2SC4178-F13	R215	1-218-270-11	METAL GLAZE	1.1K 5% 1/16W
Q502	8-729-117-72	TRANSISTOR	2SC4178-F13	R216	1-216-822-11	METAL CHIP	1.2K 5% 1/16W
Q503	8-729-807-87	TRANSISTOR	2SB1295-UL6 (SUFFIX No. 22)	R217	1-216-821-11	METAL CHIP	1K 5% 1/16W
Q504	8-729-421-77	TRANSISTOR	UN5210-R (SUFFIX No. 22)	R218	1-216-833-11	METAL CHIP	10K 5% 1/16W
Q505	8-729-402-16	TRANSISTOR	XN4608	R220	1-216-822-11	METAL CHIP	1.2K 5% 1/16W
Q506	8-729-425-89	TRANSISTOR	XP1115	R222	1-216-793-11	METAL GLAZE	4.7 5% 1/16W
Q601	8-729-809-46	TRANSISTOR	2SD1935-CT6	R301	1-218-736-11	METAL CHIP	68K 0.50% 1/16W
Q602	8-729-822-60	TRANSISTOR	2SB1302-S	R302	1-216-845-11	METAL CHIP	100K 5% 1/16W
Q604	8-729-230-60	TRANSISTOR	2SA1586-YG	R303	1-218-724-11	METAL CHIP	22K 0.50% 1/16W
Q701	8-729-421-77	TRANSISTOR	UN5210-R	R304	1-216-825-11	METAL CHIP	2.2K 5% 1/16W
Q702	8-729-426-36	TRANSISTOR	XP1215-TXE	R305	1-218-295-11	METAL GLAZE	43K 5% 1/16W
Q703	8-729-602-21	TRANSISTOR	2SC4154-F	R306	1-216-809-11	METAL CHIP	100 5% 1/16W
Q704	8-729-602-21	TRANSISTOR	2SC4154-F	R307	1-216-809-11	METAL CHIP	100 5% 1/16W
Q705	8-729-421-77	TRANSISTOR	UN5210-R	R308	1-216-829-11	METAL CHIP	4.7K 5% 1/16W
Q706	8-729-427-51	TRANSISTOR	XP4215-TXE	R309	1-216-821-11	METAL CHIP	1K 5% 1/16W
Q707	8-729-020-99	TRANSISTOR	UN5215-RS-TX	R310	1-216-849-11	METAL CHIP	220K 5% 1/16W
Q708	8-729-425-46	TRANSISTOR	XP4315-TXE	R311	1-216-827-11	METAL CHIP	3.3K 5% 1/16W
Q709	8-729-602-21	TRANSISTOR	2SC4154-F	R312	1-216-845-11	METAL CHIP	100K 5% 1/16W
Q710	8-729-602-21	TRANSISTOR	2SC4154-F (JE SUFFIX No. 21)	R314	1-216-825-11	METAL CHIP	2.2K 5% 1/16W
< RESISTOR >				R315	1-216-793-11	METAL GLAZE	4.7 5% 1/16W
R103	1-216-839-11	METAL CHIP	33K 5% 1/16W	R316	1-216-831-11	METAL CHIP	6.8K 5% 1/16W
R104	1-216-812-11	METAL CHIP	180 5% 1/16W	R322	1-216-809-11	METAL CHIP	100 5% 1/16W
R105	1-216-831-11	METAL CHIP	6.8K 5% 1/16W	R501	1-216-829-11	METAL CHIP	4.7K 5% 1/16W
R106	1-216-847-11	METAL CHIP	150K 5% 1/16W	R502	1-216-857-11	METAL CHIP	1M 5% 1/16W
R107	1-216-839-11	METAL CHIP	33K 5% 1/16W	R503	1-216-853-11	METAL CHIP	470K 5% 1/16W
R108	1-216-839-11	METAL CHIP	33K 5% 1/16W	R504	1-216-821-11	METAL CHIP	1K 5% 1/16W
R109	1-216-834-11	METAL CHIP	12K 5% 1/16W	R505	1-216-841-11	METAL CHIP	47K 5% 1/16W (SUFFIX No. 22)
R110	1-216-852-11	METAL CHIP	390K 5% 1/16W	R506	1-216-821-11	METAL CHIP	1K 5% 1/16W
R111	1-216-825-11	METAL CHIP	2.2K 5% 1/16W	R507	1-216-853-11	METAL CHIP	470K 5% 1/16W
R113	1-216-825-11	METAL CHIP	2.2K 5% 1/16W	R508	1-216-833-11	METAL CHIP	10K 5% 1/16W
R114	1-216-824-11	METAL CHIP	1.8K 5% 1/16W	R509	1-216-841-11	METAL CHIP	47K 5% 1/16W
R115	1-218-270-11	METAL GLAZE	1.1K 5% 1/16W	R510	1-218-484-11	METAL GLAZE	750 5% 1/16W
R116	1-216-822-11	METAL CHIP	1.2K 5% 1/16W	R511	1-216-836-11	METAL CHIP	18K 5% 1/16W
R117	1-216-821-11	METAL CHIP	1K 5% 1/16W	R512	1-216-809-11	METAL CHIP	100 5% 1/16W
R118	1-216-833-11	METAL CHIP	10K 5% 1/16W	R513	1-216-809-11	METAL CHIP	100 5% 1/16W
R120	1-216-822-11	METAL CHIP	1.2K 5% 1/16W	R514	1-216-823-11	METAL CHIP	1.5K 5% 1/16W
R122	1-216-793-11	METAL GLAZE	4.7 5% 1/16W	R515	1-216-841-11	METAL CHIP	47K 5% 1/16W
				R516	1-216-830-11	METAL CHIP	5.6K 5% 1/16W

MAIN

SW FLEXIBLE (DOLBY)

SW FLEXIBLE (MODE)

Ref. No.	Part No.	Description	Remark
R517	1-216-849-11	METAL CHIP	220K 5% 1/16W (SUFFIX No. 22)
R520	1-216-853-11	METAL CHIP	470K 5% 1/16W
R524	1-216-845-11	METAL CHIP	100K 5% 1/16W
R601	1-216-815-11	METAL CHIP	330 5% 1/16W
R602	1-216-833-11	METAL CHIP	10K 5% 1/16W
R603	1-216-856-11	METAL CHIP	820K 5% 1/16W
R604	1-216-857-11	METAL CHIP	1M 5% 1/16W
R605	1-216-837-11	METAL CHIP	22K 5% 1/16W
R606	1-216-857-11	METAL CHIP	1M 5% 1/16W
R607	1-216-845-11	METAL CHIP	100K 5% 1/16W
R608	1-216-837-11	METAL CHIP	22K 5% 1/16W
R609	1-216-845-11	METAL CHIP	100K 5% 1/16W
R610	1-216-849-11	METAL CHIP	220K 5% 1/16W
R615	1-216-845-11	METAL CHIP	100K 5% 1/16W
R616	1-216-845-11	METAL CHIP	100K 5% 1/16W
R617	1-216-845-11	METAL CHIP	100K 5% 1/16W
R618	1-216-857-11	METAL CHIP	1M 5% 1/16W
R619	1-216-853-11	METAL CHIP	470K 5% 1/16W
R701	1-216-829-11	METAL CHIP	4.7K 5% 1/16W
R702	1-216-837-11	METAL CHIP	22K 5% 1/16W
R703	1-216-837-11	METAL CHIP	22K 5% 1/16W
R704	1-216-837-11	METAL CHIP	22K 5% 1/16W
R705	1-216-845-11	METAL CHIP	100K 5% 1/16W
R706	1-216-845-11	METAL CHIP	100K 5% 1/16W
R707	1-216-845-11	METAL CHIP	100K 5% 1/16W
R708	1-216-849-11	METAL CHIP	220K 5% 1/16W
R709	1-216-849-11	METAL CHIP	220K 5% 1/16W
R710	1-216-849-11	METAL CHIP	220K 5% 1/16W
R711	1-216-849-11	METAL CHIP	220K 5% 1/16W
R712	1-216-849-11	METAL CHIP	220K 5% 1/16W
R713	1-216-845-11	METAL CHIP	100K 5% 1/16W
R714	1-216-845-11	METAL CHIP	100K 5% 1/16W
R715	1-216-845-11	METAL CHIP	100K 5% 1/16W
R716	1-218-668-11	METAL CHIP	100 0.50% 1/16W
R718	1-216-849-11	METAL CHIP	220K 5% 1/16W
R719	1-216-849-11	METAL CHIP	220K 5% 1/16W
R720	1-218-724-11	METAL CHIP	22K 0.50% 1/16W
R721	1-218-836-11	METAL CHIP	360 0.50% 1/16W
R722	1-218-845-11	METAL CHIP	820 0.50% 1/16W
R723	1-218-692-11	METAL CHIP	1K 0.50% 1/16W
R724	1-218-694-11	METAL CHIP	1.2K 0.50% 1/16W
R725	1-218-851-11	METAL CHIP	1.5K 0.50% 1/16W
R726	1-216-853-11	METAL CHIP	470K 5% 1/16W
R727	1-216-821-11	METAL CHIP	1K 5% 1/16W
R728	1-218-714-11	METAL CHIP	8.2K 0.50% 1/16W
R729	1-216-841-11	METAL CHIP	47K 5% 1/16W
R730	1-216-837-11	METAL CHIP	22K 5% 1/16W
R731	1-216-845-11	METAL CHIP	100K 5% 1/16W
R732	1-216-857-11	METAL CHIP	1M 5% 1/16W

Ref. No.	Part No.	Description	Remark
R733	1-216-853-11	METAL CHIP	470K 5% 1/16W (JE SUFFIX No. 21)
R734	1-216-849-11	METAL CHIP	220K 5% 1/16W
R735	1-216-845-11	METAL CHIP	100K 5% 1/16W
R736	1-218-708-11	METAL CHIP	4.7K 0.50% 1/16W
R737	1-216-849-11	METAL CHIP	220K 5% 1/16W
R738	1-216-853-11	METAL CHIP	470K 5% 1/16W
R739	1-216-857-11	METAL CHIP	1M 5% 1/16W
R740	1-216-849-11	METAL CHIP	220K 5% 1/16W
R741	1-216-857-11	METAL CHIP	1M 5% 1/16W
R742	1-216-841-11	METAL CHIP	47K 5% 1/16W
R756	1-216-849-11	METAL CHIP	220K 5% 1/16W
< VARIABLE RESISTOR >			
RV301	1-223-711-21	RES, VAR (VOL)	
RV601	1-223-715-21	RES, ADJ 220K	
< SWITCH >			
S701	1-572-581-11	SWITCH, SLIDE (N/R DETECT)	
S703	1-692-933-41	SWITCH, PUSH (1 KEY) (A/B DETECT)	
S704	1-692-849-21	SWITCH, PUSH (1 KEY) (TAPE)	
S705	1-692-453-11	SWITCH, KEY BOARD (□)	
S706	1-692-453-11	SWITCH, KEY BOARD (<▷>)	
S707	1-692-453-11	SWITCH, KEY BOARD (FF)	
S708	1-692-453-11	SWITCH, KEY BOARD (REW)	
S709	1-692-453-11	SWITCH, KEY BOARD (BAND)	
S710	1-692-453-11	SWITCH, KEY BOARD (ASP)	
< VIBRATOR >			
X501	1-577-262-11	VIBRATOR, CRYSTAL (72kHz)	
X701	1-579-867-21	VIBRATOR, CERAMIC (2MHz)	

1-653-416-11 SW FLEXIBLE (DOLBY) BOARD			

< SWITCH >			
S901	1-572-922-11	SWITCH, SLIDE (DOLBY NR)	

1-654-523-11 SW FLEXIBLE (MODE) BOARD			

< SWITCH >			
S902	1-572-922-11	SWITCH, SLIDE (BL SKIP)	

TUNER FLEXIBLE **TUNER UNIT**

Ref. No.	Part No.	Description	Remark	Ref. No.	Part No.	Description	Remark
	1-654-522-11	TUNER FLEXIBLE BOARD *****				ACCESSORIES & PACKING MATERIALS *****	

	1-693-265-11	TUNER UNIT *****			1-467-776-11	REMOTE CONTROL UNIT	
		< FILTER >		△	1-528-539-11	BATTERY CASE	
				△	1-528-579-11	BATTERY CHARGER (BC-9HG) (AUS)	
					1-528-580-11	BATTERY CHARGER (BC-7HT) (E, JE)	
					1-528-590-11	BATTERY, NICKEL HYDROGEN	
				△	1-569-007-11	ADAPTER, CONVERSION 2P (E, JE)	
CF1	1-579-214-21	FILTER, CERAMIC		*	3-376-784-01	CUSHION (E, AUS)	
CF2	1-579-214-21	FILTER, CERAMIC		*	3-376-784-11	CUSHION (JE)	
CF3	1-760-522-21	FILTER, CERAMIC			3-759-775-11	MANUAL, INSTRUCTION (ENGLISH, SPANISH, CHINESE) (E, AUS)	
		< DIODE >			3-759-775-41	MANUAL, INSTRUCTION (JAPANESE, ENGLISH) (JE)	
D2	8-719-050-97	DIODE MA357(E)-(EX).SO			3-759-775-51	MANUAL, INSTRUCTION (KOREAN) (JE)	
D4	8-719-050-97	DIODE MA357(E)-(EX).SO			3-916-249-01	CASE, CARRYING	
		< IC >		*	3-919-198-01	INDIVIDUAL CARTON	
					8-953-537-90	HEADPHONE MDR-E741MP//K SET	
IC1	8-759-245-96	IC TA8182FN			X-3329-657-1	ATTACHMENT	
IC2	8-759-231-03	IC TA8153FN					
IC3	8-759-290-04	IC TA2040AFN					
		< VIBRATOR >					
X1	1-760-523-21	OSCILLATOR, CERAMIC					

		MISCELLANEOUS *****					
19	1-693-265-11	TUNER UNIT					
20	1-654-522-11	TUNER FLEXIBLE BOARD					
59	1-653-416-11	SW FLEXIBLE (DOLBY) BOARD					
60	1-654-523-11	SW FLEXIBLE (MODE) BOARD					
62	1-653-415-11	ATS FLEXIBLE BOARD					
130	A-3042-533-A	DDC ASSY					
HP901	1-500-091-21	HEAD, MAGNETIC (PLAYBACK)					
M901	1-698-368-11	MOTOR					
PM901	1-454-674-11	SOLENOID, PLUNGER					
S901	1-572-922-11	SWITCH, SLIDE (DOLBY NR)					
S902	1-572-922-11	SWITCH, SLIDE (BL SKIP)					
S903	1-572-580-11	SWITCH, LEAF (ATS)					

The components identified by mark △ or dotted line with mark △ are critical for safety. Replace only with part number specified.

